

## VECTRA SST3

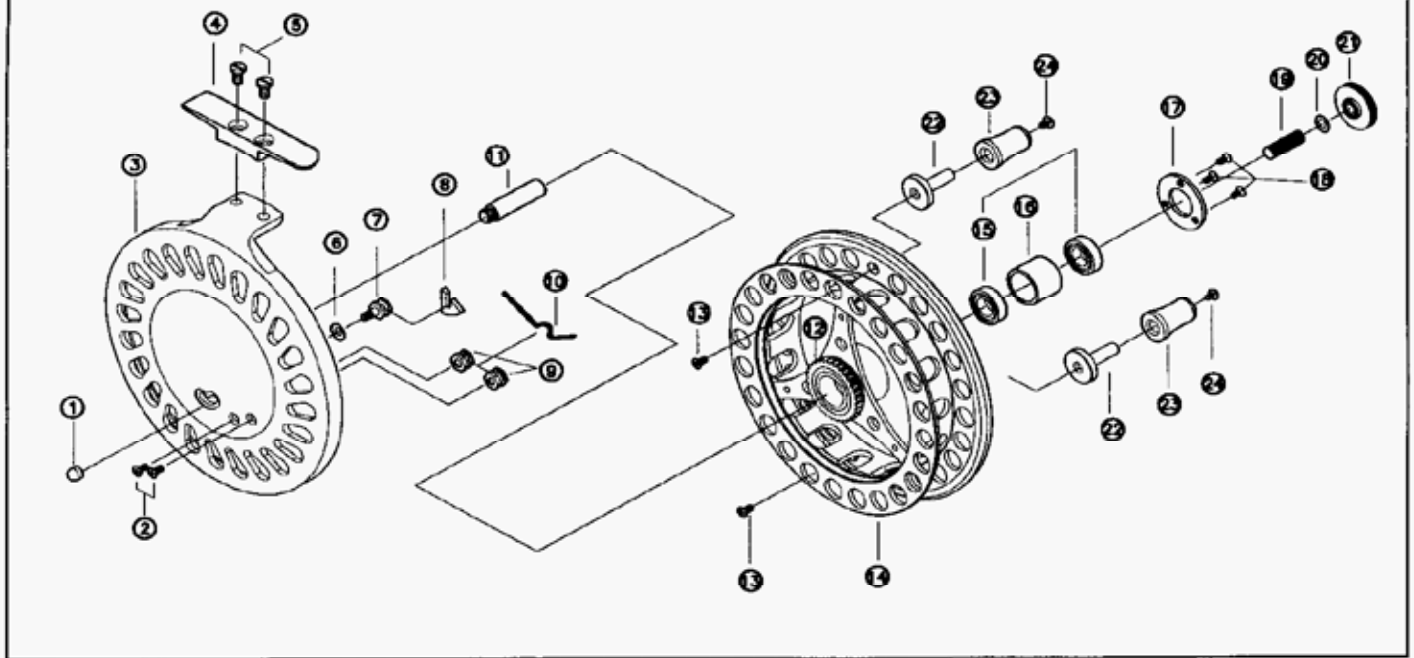

No.	PART NAME	No.	PART NAME	No.	PART NAME	No.	PART NAME	No.	PART NAME
1	RATCHET SWITCH	6	WASHER(PAWL CARRIER)	11	MAIN SHAFT	16	BUSH	21	SPOOL CAP
2	SCREW(SUPPORT)	7	PAWL CARRIER	12	CLICK GEAR	17	BRG CLAMP PLATE	22	HANDLE RVET
3	FRAME	8	CLICK CLAW	13	HANDLE KNOB S/C	18	PLATE SCREW	23	HANDLE KNOB
4	FOOT	9	SPRING SUPPORT	14	SPOOL	19	SCREW(CAP)	24	HANDLE KNOB SCREW
5	SCREW(FOOT)	10	SPRING	15	BALL BEARING	20	O-RING		

## 5 Year Warranty Against Manufacturing Defects

Raven float reels are manufactured to exacting specifications. We proudly offer the original owner our five (5) year warranty against manufacturing defects, fully backed by our unparalleled customer service.

The reel, and dated proof of purchase, must be returned postage paid to the Raven Warranty Centre for repair. Return shipping charges and taxes will apply. Please note any misuse, damage, modification or unauthorized repair automatically forfeits this warranty.

For warranty issues and shipping instructions, please contact your local Authorized Raven dealer or e-mail us directly at: [service@raventackle.com](mailto:service@raventackle.com).

We reserve the right to modify this warranty without notice.

## Maintenance Information

**Maintenance** - Raven float reels are designed to require minimal maintenance. After each use, wipe the reel down with a soft, damp cloth. Pay particular attention to the inner edge of the spool and the inside edge of the back plate. Any grit that is trapped there may result in a grinding or gritty noise. Periodic application of grease in the clicker system will ensure smooth functioning.

**Bearings** - The bearings are pre-lubricated and double-shielded for protection against grit and other contaminants. Avoid adding lubricants to the bearings, which may negatively affect their performance. Keeping the bearings free from grit and water will ensure their optimal performance. If the bearings no longer run effectively, replacement bearings can be special ordered by your local Authorized Raven Dealer.

**Clicker Assembly** - Engage the clicker by sliding the clicker button down and to the side. The clicker helps hold the spool from spinning freely while the reel is not in use. It is not intended for use as a drag mechanism.

**Adjustable Tension Front Cap Screw** - To tune the spool to spin as desired, simply tighten or loosen the front cap by a fraction of a turn. **AVOID OVER-TIGHTENING**, as this may damage the bearings.

**Removable Spool** - Completely unscrew the front cap and slide the spool off the spindle.